

CS1-D507S

Closed Loop Stepper Drive

User Manual



Revision 1.0

©2019 Leadshine Technology Co., Ltd.

Notice

Read this manual carefully before any assembling and using. Incorrect handling of products in this manual can result in injury and damage to persons and machinery. Strictly adhere to the technical information regarding installation requirements.

This manual is not for use or disclosure outside of Leadshine except under permission. All rights are reserved. No part of this manual shall be reproduced, stored in retrieval form, or transmitted by any means, electronic, mechanical, photocopying, recording, or otherwise without approval from Leadshine. While every precaution has been taken in the preparation of the book, Leadshine assumes no responsibility for errors or omissions. Neither is any liability assumed for damages resulting from the use of the information contained herein.

This document is proprietary information of Leadshine that is furnished for customer use ONLY. Information in this document is subject to change without notice and does not represent a commitment on the part of Leadshine. Therefore, information contained in this manual may be updated from time-to-time due to product improvements, etc., and may not conform in every respect to former issues.

Record of Revisions

Revision	Date	Description of Release
<i>1.00</i>	<i>Aug, 2019</i>	<i>Initial Release</i>
<i>1.1</i>	<i>Mar, 2020</i>	<i>Modified the configuration of S1 rotating switch;</i>

Table of Content

1. Introduction.....	1
1.1 Features.....	1
1.2 Applications.....	2
2. Specifications.....	2
2.1 Electrical Specifications.....	2
2.2 Environment.....	2
2.3 Mechanical Specifications.....	3
2.4 Heat Dissipation.....	3
3. Connections and LED Indication.....	4
3.1 P1 – Control and Digital Output Connections.....	4
3.2 P2 - Encoder Signal Input Connector.....	6
3.3 P3 - Motor Connector.....	6
3.4 P4 - Power Connector.....	6
3.5 P5 - Tuning Port.....	7
3.6 Status LED Lights.....	7
3.7 Switches.....	7
4. Motor Selection.....	8
5. Power Supply Selection.....	8
5.1 Regulated or Unregulated Power Supply.....	8
5.2 Power Supply Sharing.....	8
5.3 Selecting Supply Voltage.....	8
6. Switch Configurations.....	9
6.1 S1 - Rotating Switch Configurations.....	9
6.2 S2 - DIP Switch Configurations.....	9
6.2.1 Micro Step (SW1-SW4).....	10
6.2.2 Mode Setting (SW5 - SW8).....	11

6.2.3 Smoothing Filter Time Configuration (SW9-SW10).....	11
6.2.4 Encoder Resolution Configuration (SW11-SW12).....	11
6.3 S3 - Selector Switch Configurations.....	12
7. Typical Connection.....	12
7.1 Digital Input Connection.....	13
7.2 Digital Output Connection.....	14
7.2.1 In position and Fault Output Connection.....	14
7.2.2 Encoder Output Connection.....	14
7.2.3 Brake Output Connection.....	14
8. Sequence Chart of Control Signals.....	14
9. Fault Protections.....	15
10. Software Configuration.....	16
11. Accessories.....	16
12. Troubleshooting.....	16
13. Warranty.....	19

1. Introduction

Leadshine CS1-D507S are closed loop stepper drives designed to solve the loss of step problem in open loop stepper control systems, thus increase system reliability at minimal cost increase. It implements advanced control algorithm of Leadshine based on its tens of years' experience in stepper and servo controls. The CS1-D507S are highly reliable and affordable and performs excellent in many industrial applications such as CNC, medical, electronics, packaging...

The CS1-D507S can power 2-phase NEMA 17, 23, and 24 stepper motors with incremental encoders. Compared with traditional open loop stepper systems, the CS1-D507S adopted closed loop step system can eliminate potential loss of step, make real-time position error correction, and do not need torque reservation (100% torque implementation). Also it can power the driven stepper motor with reduced heating, lower noise, low vibration...

1.1 Features

- No loss of step
- No torque reservation
- No hunting or overshooting
- No tuning for easy setup
- Enhance performance at low speed application(30-120 RPM)
- 20-50VDC supply voltage, max 7A output current
- Max 500 KHz input frequency
- Brake output does not need to connect a relay

Inputs and Outputs

- Step & DIR (CW & CCW) inputs
- Enable input and Error Reset input
- Alarm output and In Position output
- Brake outputs
- Encoder A/B/Z outputs

Protections

- Over current
- Over voltage
- Motor connection error
- Encoder connection error
- Position following error
- ROM error
- Auto-tuning error

Switch Setting

- Microstep resolution
- Rotation direction
- Pulse Mode
- Positional command filter
- Closed / Open Loop Mode
- Encoder resolution
- Gain adjustment and output current
- 5V or 24V control signal voltage selector

Software Tuning

- Output current
- Input/Output signals level
- Motion parameters
- Brake parameters

1.2 Applications

When a CS1-D507S closed loop stepper drive is implemented with a compatible stepper motor with encoder, the closed stepper system can be adopted in many small to median speed applications such as CNC routers, CNC mills, CNC laser cutters, CNC plasma, lab automation instruments, plotters, medical equipment, electronic equipment, small packaging machines, etc.

2. Specifications

2.1 Electrical Specifications

Parameters	Min	Typical	Max	Unit
Peak Current	0.5	6.0	7.0 (Peak)	A
Operating Voltage	20	24, 36, 48	50	VDC
Logic input signal current	7	10	16	mA
Pulse input frequency	0	-	500	kHz
Brake output signal current	-	-	500	mA
Alarm output voltage	-	-	24	VDC
Minimal pulse width	1.0	-	-	μS
Minimal direction setup	2.0	-	-	μS
Isolation resistance	500			MΩ

2.2 Environment

Cooling	Natural Cooling or Forced Cooling	
Operating Environment	Environment	Avoid dust, oil fog and corrosive gases
	Humidity	40%RH – 90%RH
	Operating Temperature	0°C – 50°C (32°F - 122°F)
	Vibration	10-50Hz / 0.15mm
Storage Temperature	-20°C – 65°C (-4°F - 149°F)	
Weight	Approx. 280 g (9.9 Oz)	

2.3 Mechanical Specifications

(unit: mm [1inch=25.4mm])

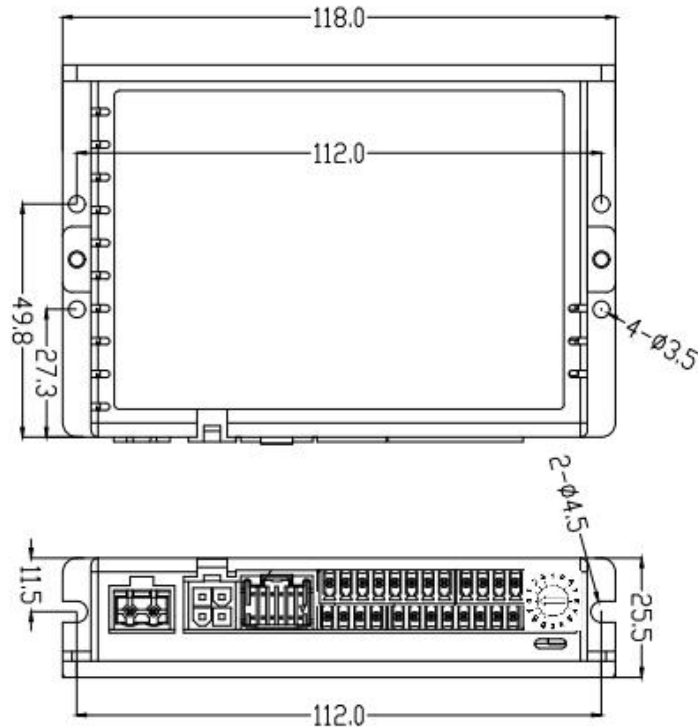

Figure 1: Mechanical specifications

2.4 Heat Dissipation

- CS1-D507S reliable working temperature should be no more than 60°C (140°F)
- It is recommended to mount the drive vertically to maximize heat dissipation. Mount a cooling fan nearby if necessary.
- If multiple CS1-D507S drives are installed, it is suggested to keep a minimal 30mm (1.2 inches) between two of them.

3. Connections and LED Indication

A CS1-D507S closed loop stepper drive has 5 connection blocks from P1 to P5 (see figure 2).

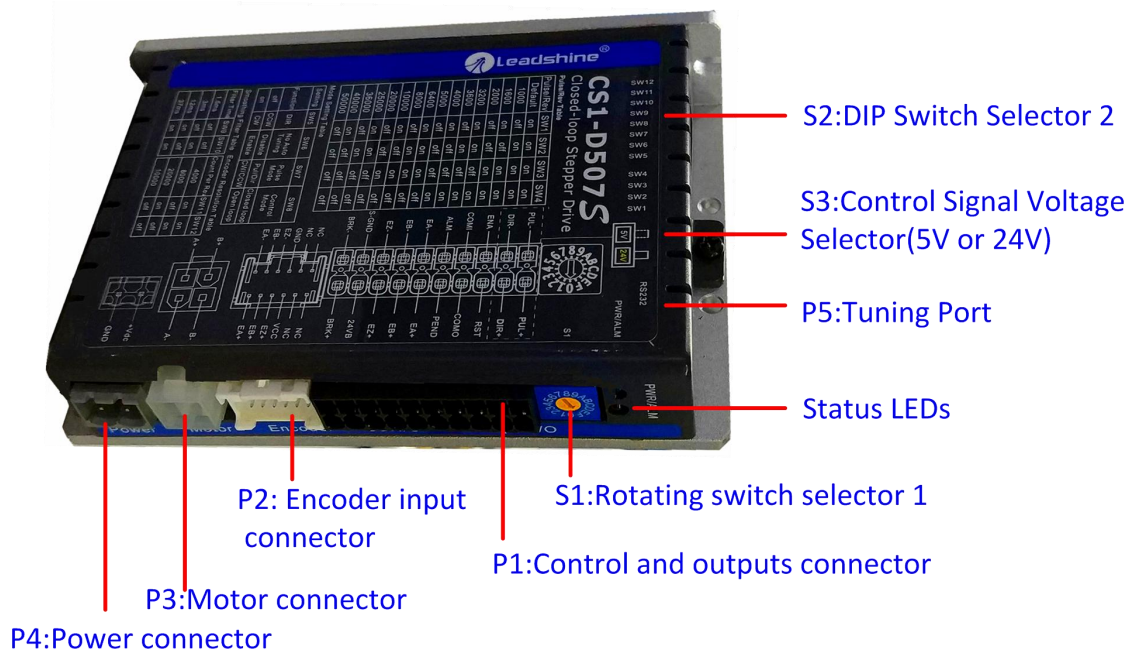

Figure 2: CS1-D507S connectors

3.1 P1 – Control and Digital Output Connections

The P1 connector in Figure 2 contains connections for control signals and a configurable digital output.

See the following table for details.

PIN	I/O	Details
PUL+ (CW+)	I	<u>Pulse and Direction Connection:</u> (1) Optically isolated, high level 3.5-5V or 24V, low voltage 0-0.5V (2) Maximum 500 KHz input frequency (3) The width of PUL signal is at least 1.0 μ s, duty cycle is recommended 50% (4) Single pulse (step & direction) or double pulse (CW/CCW) is set by DIP Switch SW7 (5) DIR signal requires advance PUL signal minimum 2 μ s in single pulse mode (6) The factory setting of control signal voltage is 24V, must need to set S3 (figure 2) if it is 5V
PUL- (CW-)	I	
DIR+ (CCW+)	I	
DIR- (CCW-)	I	

RST	I	<p><u>Alarm Reset and Enable Signals:</u> Optional.</p> <p>(1) RST means alarm reset, ENA means Enable. Optically isolated, single-ended.</p>
ENA	I	<p>(2) RST and ENA: Effective high level is 3.5-24V; Effective low level is 0-0.5V connection</p> <p>(3) RST signal can clear the alarm of “Position following error” and “Fail to lock motor shaft”, other alarms require the power supply to be restarted</p> <p>(4) ENA signal requires advance DIR signal minimum 2μs in single pulse mode, (default no connection)</p>
COMI	I	Common connection of single-end input signals (common-cathode and common-anode)
COMO	O	Common connection of single-end output signals (common-cathode)
PEND	O	<p><u>In Position and Alarm :</u> They takes a sinking or sourcing 100mA current at 5-24V. Max 30V</p>
ALM	O	
EAO+	O	Encoder A+ output
EAO-	O	Encoder A- output
EBO+	O	Encoder B+ output
EBO-	O	Encoder B- output
EZO+	O	<p>Encoder Z +/- output, optional. Only if the closed-loop motor has Z signal input to CS1-D507S, the CS1-D507S will have Z signal output to controller or PLC</p>
EZO-	O	
24VB	I	Used for brake signal, connect with +24 DC of external power supply, refer to chapter 7.2.3
BRK+	O	Brake+ signal, Max. 24/500mA, connect with brake coil.
BRK-	O	Brake- signal, Max. 24/500mA, connect with brake coil. It's shown as SO7 in Leadshine ProTuner and level cannot be modified
S-GND	O	Signal GND

Notes: (1) Shielding control signal wires is suggested; (2) To avoid/reduce interference, don't tie control signal cables and power wires together; (3) Brake output does not need to connect a relay

3.2 P2 - Encoder Signal Input Connector

The P2 connector in Figure 2 is for encoder signal connection. Refer to the following table for details.

Drive Pin Name	Description
NC	No connection
VCC	+5V voltage for encoder
GND	Power ground connection
EZ+	Encoder Z+ input connection
EZ-	Encoder Z- input connection
EB+	Encoder B+ input connection
EB-	Encoder B- input connection
EA+	Encoder A+ input connection
EA-	Encoder A- input connection

3.3 P3 - Motor Connector

PIN	Details
A+	Connect to motor A+ wire
A-	Connect to motor A- wire
B+	Connect to motor B+ wire
B-	Connect to motor B- wire

3.4 P4 - Power Connector

Pin	Details
GND	Connect to power supply ground connection.
+VDC	Connect to power supply positive connection. Suggest 24-48VDC power supply voltage



Warning: Don't plug/unplug P3 or P4 connector to avoid drive damage or injury while powered on.

3.5 P5 - Tuning Port

CS1 series has a tuning port with RS232 to modify the drive parameters, it's only for tuning, not for equipment control because neither precision nor stability is sufficient. If you need a field bus drive, use a Leadshine RS485 or EtherCAT type drives:

<http://www.leadshine.com/ProductSubType.aspx?type=products&category=stepper-products&producttype=stepper-drives&subtype=network-stepper-drives>

The interface definition is as follows:

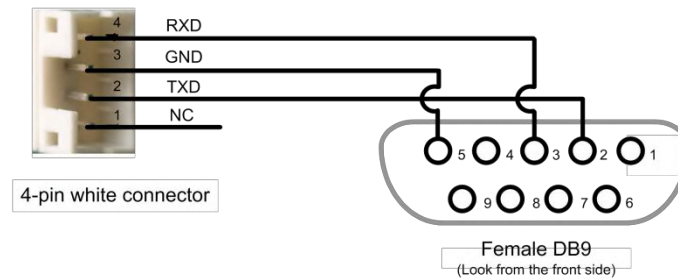

Figure 3: CABLE-PC-1 connectors

3.6 Status LED Lights

There are two LED lights for CS1 Series. The GREEN one is the power indicator which should be always on in normal circumstance. The RED one is a drive status indication light, which will be OFF while working normally but ON and flash 1 or 2 times in a 3-second period in the case of enabled over-current or over-voltage protection.

3.7 Switches

The CS1-D507S has one rotating switch, one 12-bit DIP switch and one 1-bit selector switch.

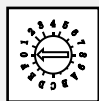
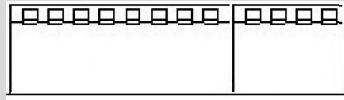
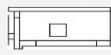
Switch	Pic	Details
Rotating switch S1		Drive Peak Current and Gain adjustment
DIP switch S2		Microstep resolution Rotation direction Pulse Mode Positional command filter Closed / Open Loop Mode Encoder resolution
Selector switch S3		5V or 24V control signal voltage selector. The factory setting is 24V, must need to set S3 to 5V if the control signal voltage is 5V

4. Motor Selection

The CS1-D507S are designed to power 2-phase NEMA 17/23/24 stepper motors under 10000-line incremental encoders. Leadshine offers many high performance closed loop stepper motors.

Notes: Default closed-loop stepper motors is equipped with a 1000-line incremental encoder without Z signal, contact Leadshine for stepper motor with 2500-line, 5000-line encoders and with Z (Index) signal.

5. Power Supply Selection

The CS1-D507S can power small and medium size closed loop stepper motors (frame size from NEMA17 to 24) from Leadshine. To get good system performance, it is important to select proper supply voltage and output current. Generally speaking, supply voltage determines the high speed performance of the motor, while output current determines the output torque of the driven motor (particularly at lower speed). Higher supply voltage will allow higher motor speed to be achieved, at the price of more noise and heating. If the motion speed requirement is low, it's better to use lower supply voltage to decrease noise, heating and improve reliability.

5.1 Regulated or Unregulated Power Supply

Both regulated and unregulated power supplies can be used to supply the drive. However, unregulated power supplies are preferred due to their ability to withstand current surge and fast response for current change. If you prefer to a regulated power supply, it is suggested to choose such a power supply specially designed for stepper/servo controls such as Leadshine RPS series (<http://www.leadshine.com/producttypes.aspx?producttype=regulated-switching>). Or, in the case when only normal switching power supplies are available, it is important to use "OVERSIZE" high current output rating power supplies (for example, using a 4A power supply for 3A stepper motor) to avoid problems such as current clamp. On the other hand, if unregulated supply is used, one may use a power supply of lower current rating than that of motor (typically 50%-70% of motor current). The reason is that the drive draws current from the power supply capacitor of the unregulated supply only during the ON duration of the PWM cycle, but not during the OFF duration. Therefore, the average current withdrawn from power supply is considerably less than motor current. For example, two 3A motors can be well supplied by one power supply of 4A rating.

5.2 Power Supply Sharing

Multiple CS1-D507S drives can share one power supply to save space and reduce cost, if that power supply has enough power capacity. To avoid cross interference, connect each stepper drive directly to the shared power supply separately. To avoid cross interference, DO NOT daisy-chain connect the power supply input pins of the Drivers. Instead connect them to power supply separately.

5.3 Selecting Supply Voltage

The CS1-D507S are designed to operate within 20-50VDC voltage input. When selecting a power supply, besides voltage from the power supply power line voltage fluctuation and back EMF voltage generated during motor deceleration needs also to be taken into account. Ideally it is suggested to use a power supply with the output of 20-48VDC, leaving room for power line voltage fluctuation and back-EMF.

Higher supply voltage can increase motor torque at higher speeds, thus helpful for avoiding losing steps. However, higher voltage may cause bigger motor vibration at lower speed, and it may also cause over-voltage protection or even drive damage. Therefore, it is suggested to choose only sufficiently high supply voltage for intended applications.

6. Switch Configurations

The CS1 series has one rotating switch, one 12-bit DIP switch and one 1-bit selector switch. “Default” means that parameters can be modified by Leadshine PC software, “Factory” means that factory setting, suitable for most customer applications

6.1 S1 - Rotating Switch Configurations

This rotating switch is used to set the peak current of the drive and motion gain, from the motor phase current and application requirements. When the rotating switch code is set to 8, the user can modify the drive peak current value and Kp & Ki value through Leadshine PC software.

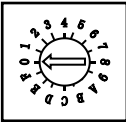
	Peak Current	Code	Velocity loop Ki	Position loop Kp	Velocity loop Kp	Remark
	4.0A	0	0	25	25	1) Recommended motors are CS-M22306 and CS-M22313;
		1	0	50	15	2) Velocity loop Ki Indicates the stop time and position accuracy , “0” indicates the stop time is long, but the position error is smaller.“16” means the stop time is short, but the position error is slightly larger.
		2	0	75	10	
		3	0	100	5	
		4	16	25	25	3) Position loop Kp and velocity loop Kp is a pair of composite parameters that represent rigidity. “25” and “25” composite parameters indicate the rigidity is weak, “100” and “5” composite parameters indicate the rigidity is strong.
		5	16	50	15	
		6	16	75	10	
		7	16	100	5	4) Usually keep factory settings
	6.0A	8(default & factory)	0	25	25	1) Recommended motors are CS-M22323, CS-M22326, CS-M22331-L, CS-M22422 and CS-M22430;
		9	0	50	15	2) Velocity loop Ki Indicates the stop time and position accuracy , “0” indicates the stop time is long, but the position error is smaller.“16” means the stop time is short, but the position error is slightly larger.
		A	0	75	10	
		B	0	100	5	
		C	16	25	25	3) Position loop Kp and velocity loop Kp is a pair of composite parameters that represent rigidity. “25” and “25” composite parameters indicate the rigidity is weak, “100” and “5” composite parameters indicate the rigidity is strong.
		D	16	50	15	
		E	16	75	10	
F		16	100	5	4) Usually keep factory settings	

6.2 S2 - DIP Switch Configurations

The 12-bit is located on the side (DIP switch S2 in Figure 2) and used to configure settings of micro step resolution, output current, and motor standstill current as shown below, the factory setting of SW1-SW12 is **ON, OFF, OFF, ON, OFF, OFF, ON, OFF, OFF, OFF, OFF, OFF**.

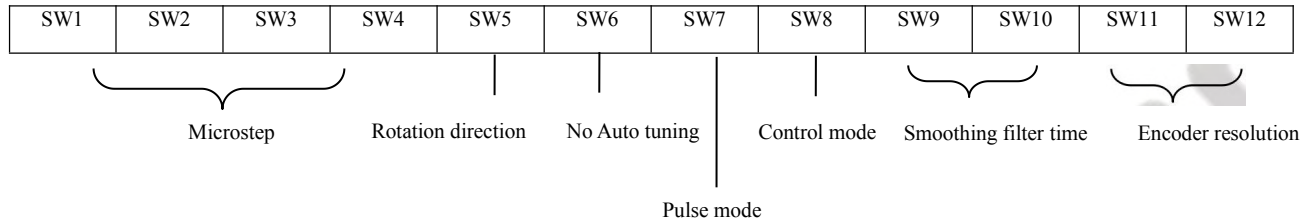

Figure 4: DIP switches

6.2.1 Micro Step (SW1-SW4)

Each CS1-D507S has 8 micro step settings which can be configured through DIP switch SW1, SW2, SW3 and SW4. See the following table for detail. When they are set to **ON, ON, ON, ON**, the microstep can be set via Leadshine PC software.

Micro step	Pulses/Rev. (for 1.8°motor)	SW1	SW2	SW3	SW4
2	400 (default)	ON	ON	ON	ON
5	1000	OFF	ON	ON	ON
8	1600	ON	OFF	ON	ON
10	2000	OFF	OFF	ON	ON
16	3200	ON	ON	OFF	ON
18	3600	OFF	ON	OFF	ON
20	4000 (factory)	ON	OFF	OFF	ON
25	5000	OFF	OFF	OFF	ON
32	6400	ON	ON	ON	OFF
40	8000	OFF	ON	ON	OFF
50	10000	ON	OFF	ON	OFF
100	20000	OFF	OFF	ON	OFF
125	25000	ON	ON	OFF	OFF
180	36000	OFF	ON	OFF	OFF
200	40000	ON	OFF	OFF	OFF
250	50000	OFF	OFF	OFF	OFF

6.2.2 Mode Setting (SW5 - SW8)

	Function	ON	OFF
SW5	Rotation Direction	CW (clockwise)	CCW (counterclockwise)
SW6	No Auto Tuning	Enable	Disable
SW7	Pulse Mode	CW/CCW (double pulse)	PUL/DIR (single pulse)
SW8	Control Mode	Open loop control	Closed loop control

6.2.3 Smoothing Filter Time Configuration (SW9-SW10)

CS1-D507S has an advanced feature called control command smoothing to make the input pulse from pulse generator (controller, PLC, etc.) S-curve acceleration, to improve motion smoothness and high-speed start frequency in many circumstances.

This is achieved through adding filtering time which is configured SW9-SW10. See the following table for how to configure. When SW9-SW10 setting is OFF, OFF, the filtering time can be set by Leadshine PC software.

Filter Time	SW9	SW10
1.5 ms (default and factory)	OFF	OFF
3 ms	OFF	ON
12 ms	ON	OFF
37 ms	ON	ON



The Filter Time value must be set to the same for each CS1-D507S in multi-axis applications

6.2.4 Encoder Resolution Configuration (SW11-SW12)

CS1-D507S can power closed loop stepper motors with incremental encoders (include and under 5000 ppr resolution), it has 2-bit DIP switch to set motor encoder resolution as below, When SW11-SW12 setting is ON, ON, the encoder resolution can be set by Leadshine PC software.

Encoder Resolution (ppr)	Count per Rev. (cpr)	SW11	SW12
1000	4000 (default)	ON	ON
2000	8000	OFF	ON
5000	20000	ON	OFF
2500	10000 (factory)	OFF	OFF

6.3 S3 - Selector Switch Configurations

The 1-bit selector is located on the top (S3 in figure 2), used to configure the voltage of control signals. For the safety of optically coupled, the factory setting is 24V, which no need to connect 2K resistors, making it easier to use. When the voltage of the control signal is 5V, the S3 must be set to 5V, otherwise, the motor won't work.

7. Typical Connection

A complete closed loop stepper system should include a stepper motor with encoder, CS1-D507S drive, power supply and controller (pulse generator). A typical connection is as below.

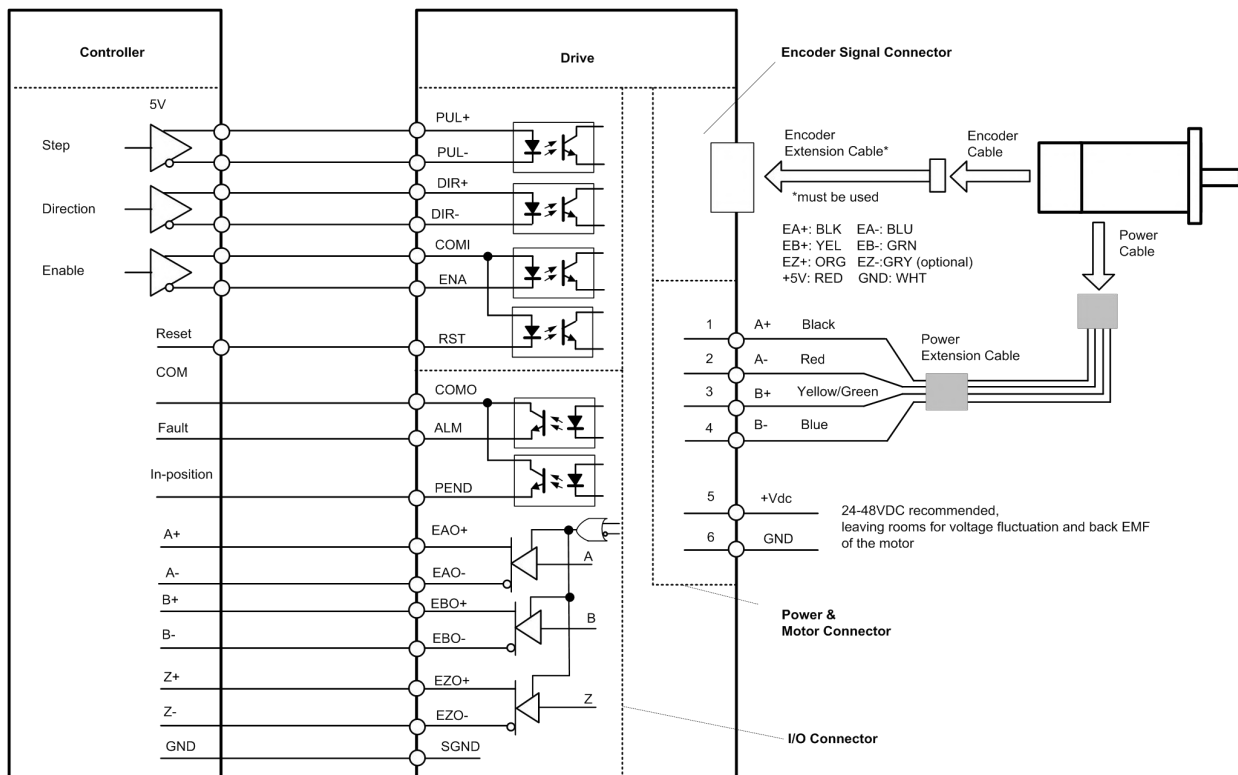

Figure 5: Typical connection

- Notes:**
- (1) If need Z signal output, please contact Leadshine for the motor and encoder extension cable with Z signal.
 - (2) Pulse and direction inputs level 5V or 24V selected by selector switch S3. When it is 24 V, the S3 selection of 5V will damage the input photo-coupling.
 - (3) Enable (ENA) and alarm reset (RST) signal is 5V~24V compatible.

7.1 Digital Input Connection

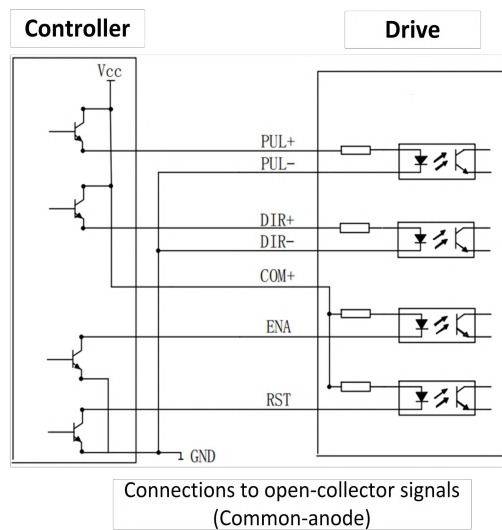
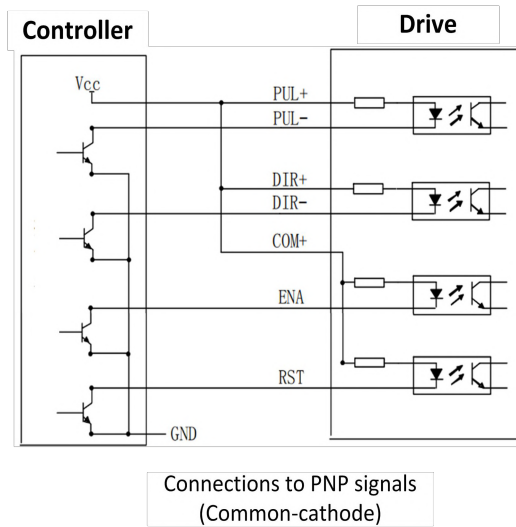
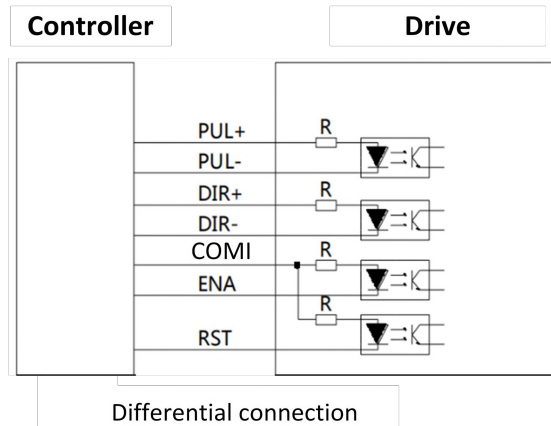

Figure 6: Digital input connections

7.2 Digital Output Connection

7.2.1 In position and Fault Output Connection

The PEND (In-position) and ALM (Alarm) can be connected either in sinking or sourcing as below:

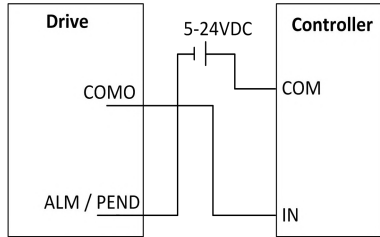

Figure 7 Sinking output

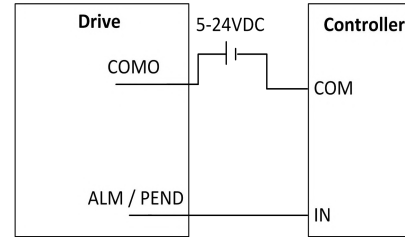

Figure 8 Sourcing output

7.2.2 Encoder Output Connection

The CS1-D507S has push-pull differential encoder output signals (EA+/-, EB+/-, EZ+/-), with AM26LS31 line driver, required current is $\pm 20\text{mA}$, can be connected to the upper controller to feedback the position information of the motor.

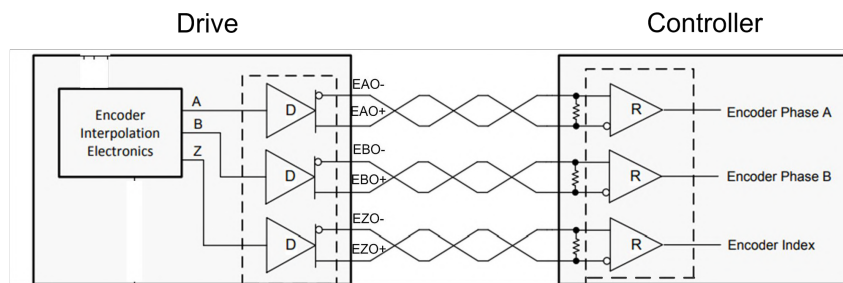

Figure 9 Encoder signals output

7.2.3 Brake Output Connection

This drive has a special brake output, built-in a fly-wheel diode, driving current up to 500 mA, can directly drive the motor brake without relays. The connection is below:

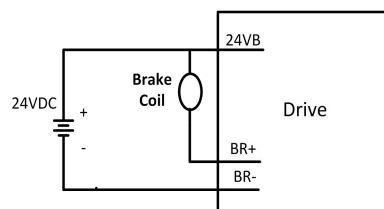

Figure 10 Brake output connection

8. Sequence Chart of Control Signals

In order to avoid some fault operations and deviations, PUL, DIR and ENA should abide by some rules, shown as following diagram:

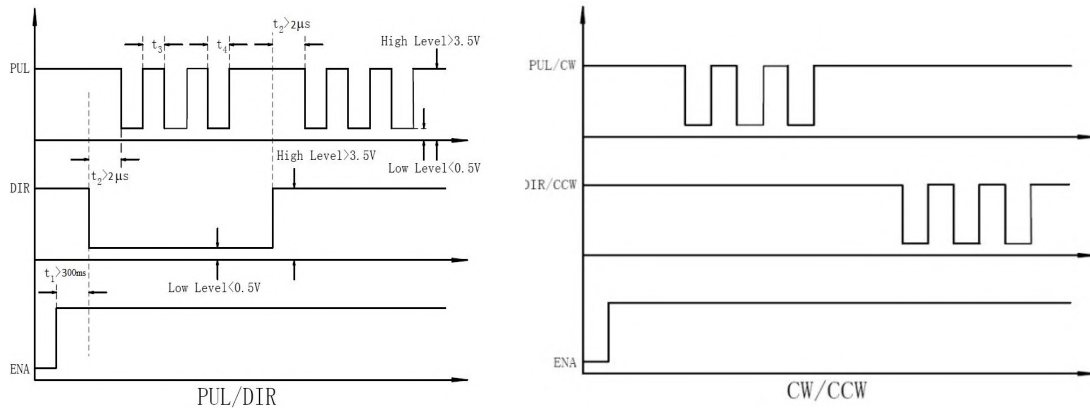

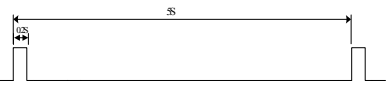
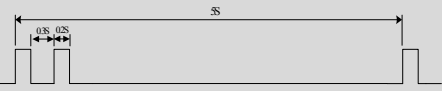

Figure 11: Sequence chart of control signals



Remark:

- t_1 : ENA must be ahead of DIR by at least 300ms. Usually, ENA+ and ENA- are NC (not connected). See “Connector P1 Configurations” for more information.
- t_2 : DIR must be ahead of PUL effective edge by 2µs to ensure correct direction;
- t_3 : Pulse width not less than 1µs;
- t_4 : Low level width not less than 1µs;
- Duty cycle of PUL signal is recommended 50%.

9. Fault Protections

To improve reliability, the drive incorporates some built-in protection features.

Blink time(s)	Sequence wave of red LED	Description	Trouble shooting
1		Over-current	Turn off the power immediately. a) Check wiring is short-circuited or not; b) Check motor is short-circuited or not.
2		Over-voltage	Turn off the power immediately. a) Check if the power voltage is higher than 90VDC
3		Chip error	Restart the power supply, if the drive is still alarm, please contact after-sale
4		Fail to lock motor shaft	a) The drive is not connected to a motor; b) If alarm is occurred when connect a motor, set DIP switch SW6 to ‘on’ and restart power supply; If it still alarm, please check the motor power cable.

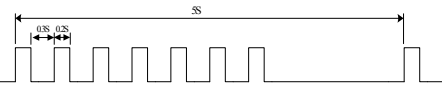
5		EEPROM error	Restart the power supply, if the drive is still alarm, please contact after-sale
6		Fail to auto tuning	Set DIP switch SW6 to 'on'
7		Position following error	a) The value of position following error is set too small; b) Motor torque is not enough or motor speed is too high; c) Motor wiring error, check wiring
Always	-	PCB board is burned out	Contact after-sale a) Power supply connection is wrong

When above protections are active, the motor shaft will be free or the red LED blinks. Reset the drive by repowering it to make it function properly after removing above problems.

10. Software Configuration

The CS1-D507S is designed for simple setup and implementation. For most applications no software configuration or tuning is needed especially when driving Leadshine stepper motors with encoders. If you want to do fine tuning or custom configurations such as micro-step, current percentage change..., you can use Leadshine's free ProTuner software to make the changes.

11. Accessories

If you plan to use the ProTuner software, contact your supplier or Leadshine to purchase the RS232 cable with part number [CABLE-PC-1](#) for connecting the CS1-D507S to a computer with Windows 7/8/10 installed. In the case of using USB to RS232 conversion, contact your supplier or Leadshine for such a cable with part number [USB2.0-232](#) which has been verified working fine.



[CABLE-PC-1](#)

(RS232 tuning cable)



[USB2.0-232](#)

(USB to RS232 Conversion Cable)

12. Troubleshooting

In the event that your drive doesn't operate properly, the first step is to identify whether the problem is electrical or

mechanical in nature. The next step is to isolate the system component that is causing the problem. As part of this process you may have to disconnect the individual components that make up your system and verify that they operate independently. It is important to document each step in the troubleshooting process. You may need this documentation to refer back to at a later date, and these details will greatly assist our Technical Support staff in determining the problem should you need assistance.

Many of the problems that affect motion control systems can be traced to electrical noise, controller software errors, or mistake in wiring.

Symptoms	Possible Problems	Solutions
Motor is not rotating	No power	Connect power supply correctly
	Microstep resolution setting is wrong	Setting appropriate microstep
	Fault condition exists	Check wiring and restart power
	The drive is disabled	Drive restore factory setting, and keep ENA+, ENA- input signals unconnected.
Wrong motor rotation direction	The Direction signal level is reverse	Toggling the SW5 DIP switch
The drive in fault	Red light flashes once in a 5-second period	The motor coil may short circuit or exiting the wrong wiring
	Red light flashes twice in a 5-second period	The power supply exceeds Max. operation voltage
	Red light flashes 7-times in a 5-second period	If using Leadshine's motor, refer to motor wiring in datasheet; If using 3 rd motor, need to swap the wiring of motor phase A+ and phase A-
	Red light is always on after power on	The drive is burned
Erratic motor motion	Control signal is too weak	Ensure the current of control signal is within 7-16mA
	Control signal is interfered	Don't tie the control signal cable with power cable together
	Wrong motor connection	Refer to user manual of drive and motor datasheet
	Something wrong with motor coil	Check the motor is normal

Motor stalls during acceleration	Current setting is too small	Choose another power supply with larger power or increase the output current of drive
	Motor is undersized for the application	Choose another motor with higher torque
	Acceleration is set too high	Reduce the acceleration
	Power supply voltage too low	Choose another power supply with large voltage output
Excessive motor & drive heating	Inadequate heat sinking / cooling	Refer to chapter 2.4
	Motor peak current setting is too high	Reduce the current value refer to motor datasheet
Motor vibration when power on	Speed loop Kp is too high	Reduce the speed loop Kp value

13. Warranty

Twelve Month Warranty

Leadshine Technology Co., Ltd. warrants its products against defects in materials and workmanship for a period of 12 months from shipment out of factory. During the warranty period, Leadshine will either, at its option, repair or replace products which proved to be defective.

Exclusions

The above warranty does not extend to any product damaged by reasons of improper or inadequate handlings by customer, improper or inadequate customer wirings, unauthorized modification or misuse, or operation beyond the electrical specifications of the product and/or operation beyond environmental specifications for the product.

Obtaining Warranty Service

To obtain warranty service, please contact your seller to obtain a returned material authorization number (RMA) before returning product for service.

Shipping Failed Products

If your product fail during the warranty period, please contact your seller for how and where to ship the failed product for warranty or repair services first, you can also e-mail customer service at to obtain a returned material authorization number (RMA) before returning product for service. Please include a written description of the problem along with contact name and address.