

## CHARACTERISTICS

The **LMBD ECO** series Linear Unit is a powerful and cost-effective Linear Unit with toothed belt drive and a Zero-backlash Ball rail guide system for easy and accurate linear movements.

It can easily be combined to multi-axis systems.

Excellent price-/performance ratio and quick delivery time are ensured.

An extruded aluminum Profile from 6063 AL with on it mounted Zero-backlash Ball rail guide system, allows high load capacities and optimal cycles for the movement of larger masses at high speed.

The linear unit LMBD ECO uses a pre-tensioned steel reinforced AT polyurethane timing toothed belt. In conjunction with a Zero-backlash drive pulley high moments with alternating loads with good positioning accuracy, low wear and low noise can be realized.

The aluminum Profile includes T-slots for fixing the Linear Unit and for attaching sensors and switches . Different carriage lengths of the Linear Unit allow the possibility to attach additional accessories on the side.

Lubrication holes on the carriage allow easy re-lubrication of the Ball rail guide .

For the linear unit LMBD ECO various adaptation options, for attaching (or redirecting), for Motors or Gearboxes are available.

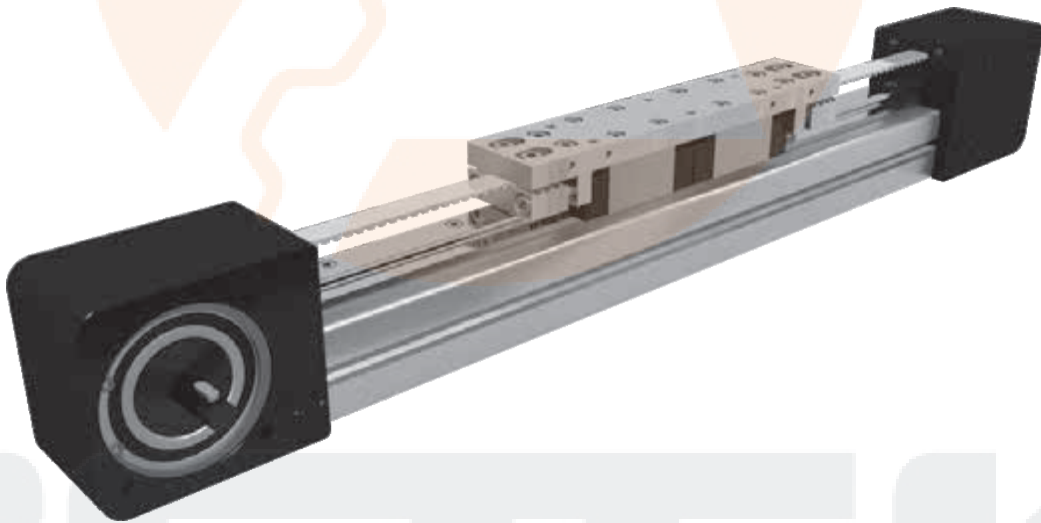

The aluminium profiles are manufactured according to the medium EN 12020-2 standard

Straightness = 0,35 mm/m; Max. torsion = 0,35 mm/m; Angular torsion = 0,2 mm/40 mm; Parallelism = 0,2 mm

**STRUCTURAL DESIGN**

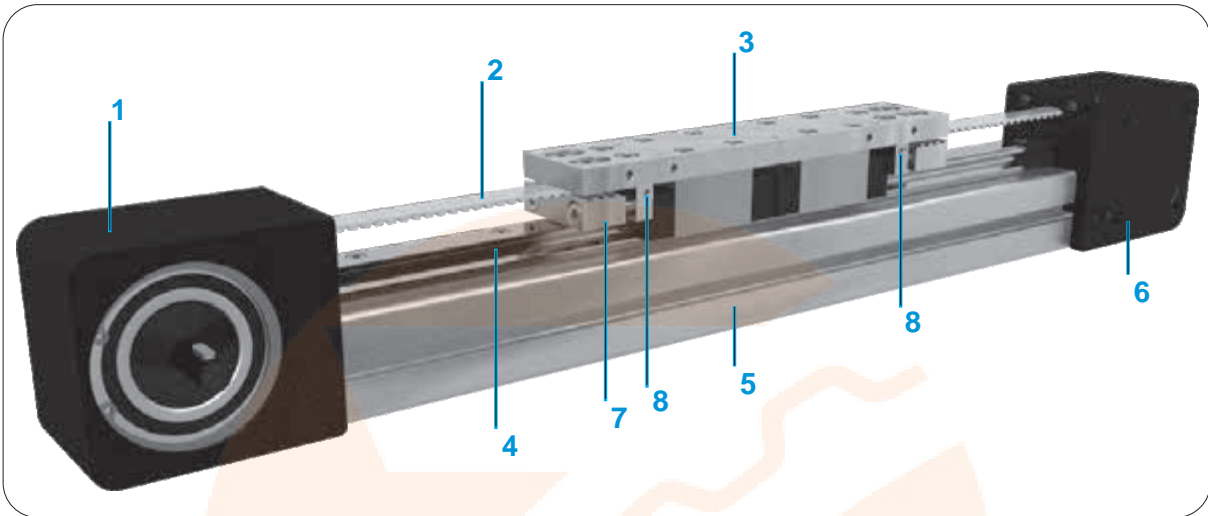

- 1 - Drive block with pulley
- 2 - AT polyurethane toothed belt with steel tension cords
- 3 - Carriage
- 4 - Linear Ball Guideway
- 5 - Aluminium profile-Hard anodized
- 6 - End block
- 7 - Belt Tension system
- 8 - Lubrication port

**HOW TO ORDER**

LMBD ECO - 
 40 - 
 1000 - 
 L - 
 1 - 
 R

Series :

**LMBD ECO**

Size :

40

Absolute stroke (mm) :

Carriage Version :

S : Short

L : Long

Type of drive pulley :

0 : Pulley with through hole

1 : Pulley with journal

10 : Pulley with journal (without Keyway)

2 : Pulley with journal on both sides

20 : Pulley with journal on both sides (without Keyway)

3 : Without drive unit

Drive journal position :

L : Journal on left side

R : Journal on right side

**Without** : For type of drive pulley 0, 2 and 3

TECHNICAL DATA

General technical data for LMBD ECO series

Linear Unit	Carriage length Lv [ mm ]	Load capacity		Dynamic moment			Moved mass [ kg ]	Maximum Repeatability [ mm ]	* Maximum length Lmax [ mm ]	Planar moment of inertia	
		Dynamic C [ N ]	Static Co [ N ]	Mx [ Nm ]	My [ Nm ]	Mz [ Nm ]				ly [ cm <sup>4</sup> ]	lz [ cm <sup>4</sup> ]
LMBD ECO 40 S	132	9329	19629	64	55	55	0,45	± 0,1	5960	9,53	9,21
LMBDECO 40 L	200	18658	39258	128	620	620	0,72	± 0,1			

\*For lengths over the stated value in the table above, please contact us.

**Recommended values of loads**

All the data of static and dynamic moments and load capacities stated in the upper table are theoretical without considering any safety factor. The safety factor depends on the application and its requested safety. We recommend a minimum safety factor (fv =5.0)

**Modulus of elasticity**

E = 70000 N / mm

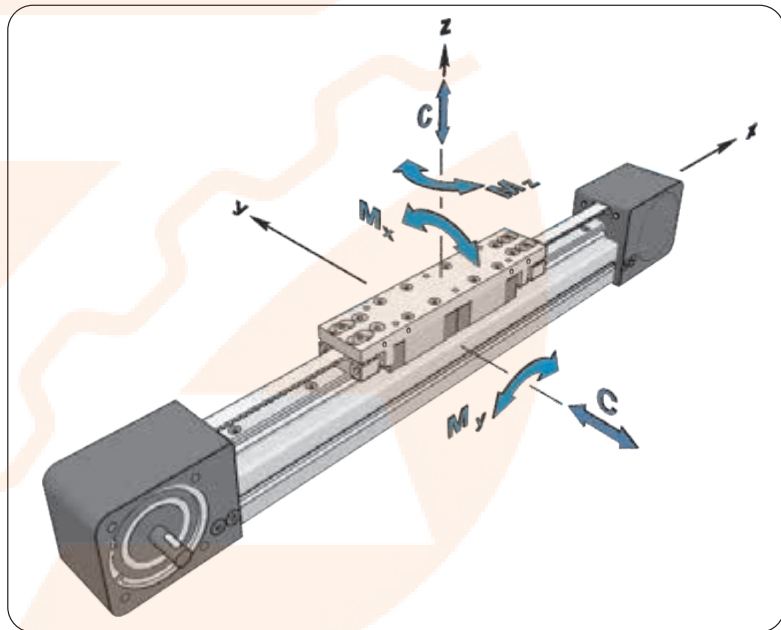

Drive and belt data

Linear Unit	Maximal travel speed [ m / s ]	Maximum drive torque [ Nm ]	* No load torque [ Nm ]	Puley drive ratio [ mm / rev ]	Pulley diameter [ mm ]	Belt type	Belt width [ mm ]	Max. force transmitted by belt [ N ]	Limit of belt elasticity [ N ]	Specific spring constant Cspec [ N ]
LMBD ECO 40 S	3	7,5	0,8	180	57,31	AT5	12	262	940	235 000
LMBD ECO 40 L			0,9							

\*The stated values are for strokes up to 500mm. No Load Torque value increases with stroke elongation

Mass and mass moment of inertia

Linear Unit	Carriage length Lv [ mm ]	Mass of linear unit [ kg ]	Mass moment of inertia [ 10 <sup>-5</sup> kg·m <sup>2</sup> ]
LMBD ECO 40 S	132	3,1 + 0,003 * Stroke [ mm ]	70,1 + 0,007 * Stroke [ mm ]
LMBD ECO 40 L	200	3,55 + 0,003 * Stroke [ mm ]	92,3 + 0,007 * Stroke [ mm ]

Mass calculation doesn't include mass of motor, reduction gear, switches and clamps.

**DIMENSIONS**

Linear Unit doesn't include any safety stroke.

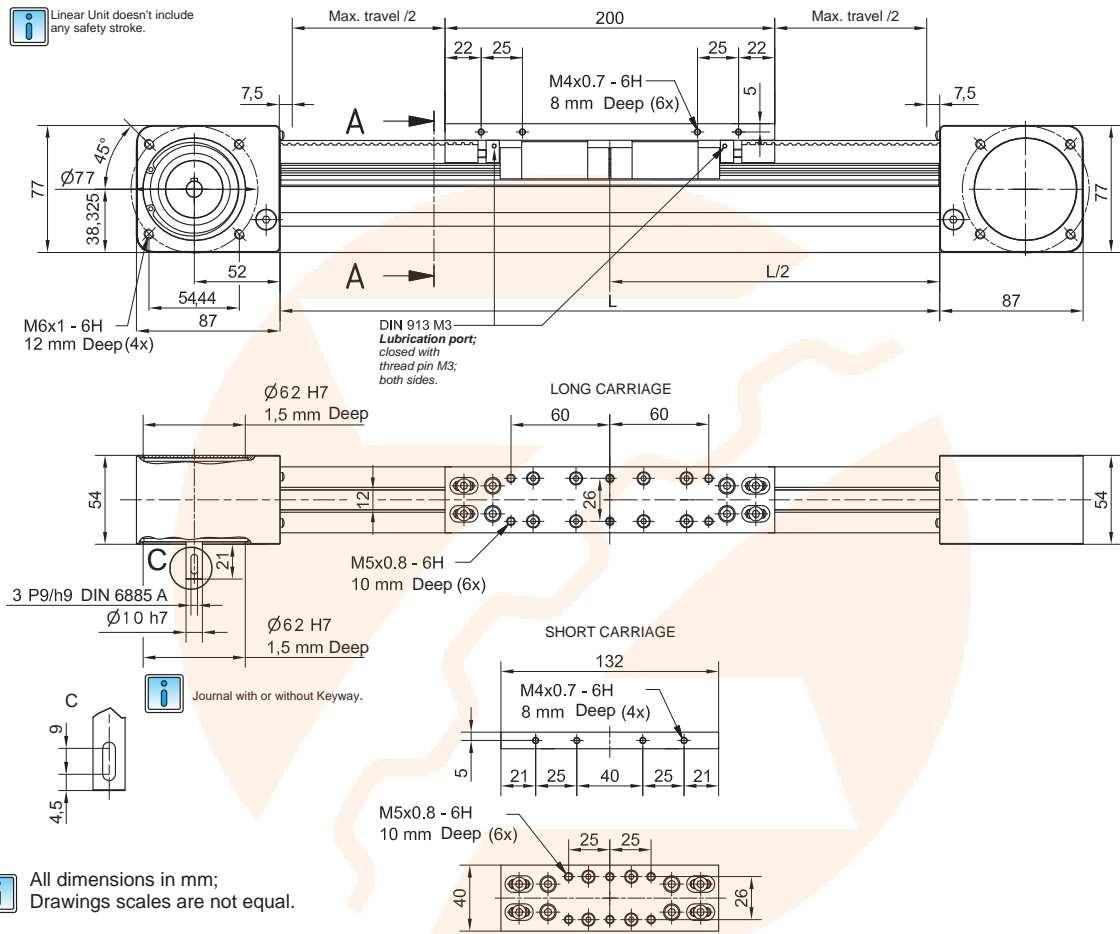

**TYPE 0**

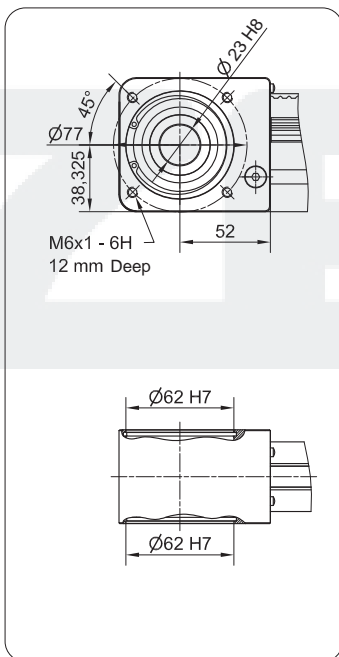

**TYPE 1 L and 1 R**

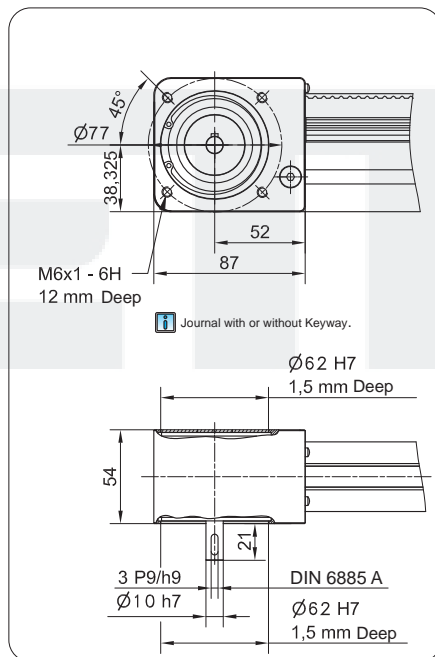

**TYPE 2**

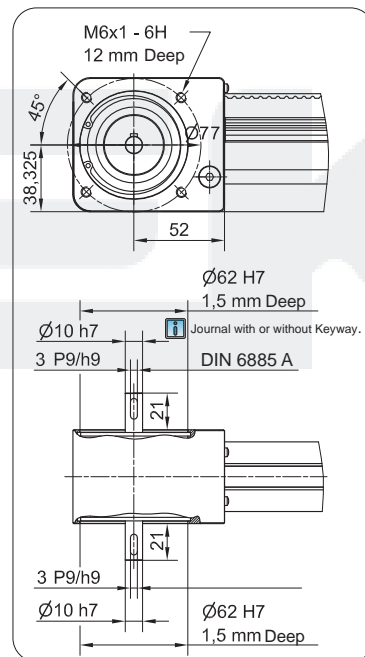

TECHNICAL DATA

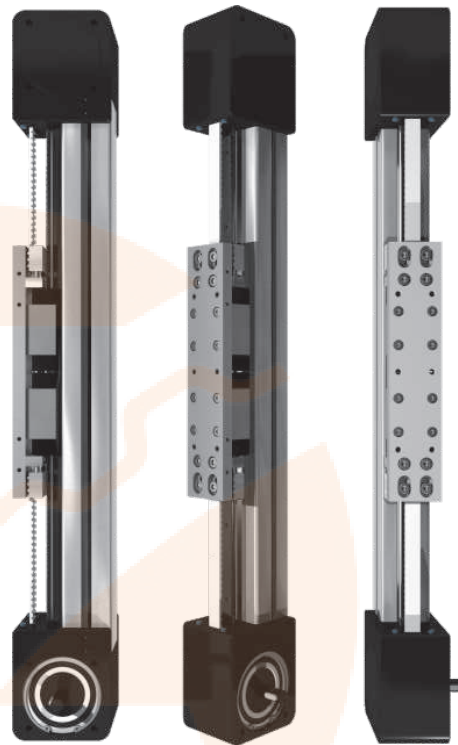
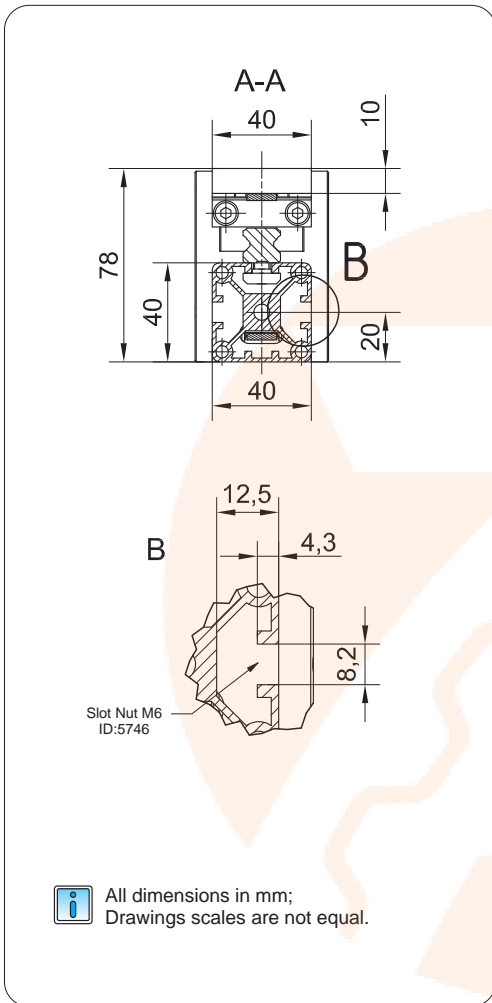

**MOTOR**

LMBD 40 ECO

Available on request

**GEAR REDUCER + MOTOR**

LMBD 40 ECO

Available on request

**GEAR REDUC. 90° + MOTOR**

LMBD 40 ECO

Available on request

Defining of the linear module length

$L = \text{Effective stroke} + 2 \times \text{Safety travel} + L_v + 15 \text{ mm}$

$L_v - \text{Long carriage} = 200 \text{ mm}$

$L_{total} = L + 174 \text{ mm}$

$L_v - \text{Short carriage} = 132 \text{ mm}$

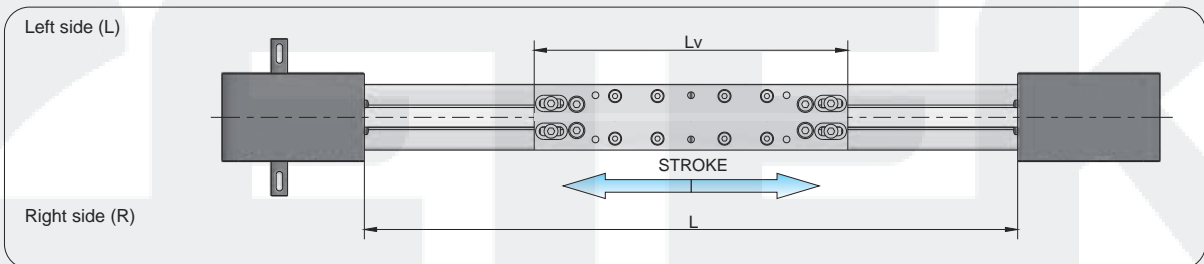

Double Carriage

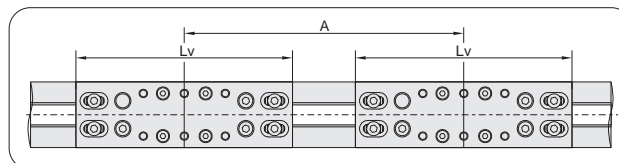

For ordering code please contact us.

$L = \text{Effective stroke} + 2 \times \text{Safety travel} + L_v + A + 15 \text{ mm}$

$A \geq L_v$

$L_{total} = L + 174 \text{ mm}$